

Infrared Interactive Flat Panels

ITATOUCH adopt the updated Infrared multi-touch technology 10~40 points, finger, any object touch

Android 14.0 OS IOS with 4GB /8GB RAM and 32GB /128GB Storage, set dual system, infrared touch, option 13 /48megpixels UHD 4K Camera (AI option) , and 8-array Microphone.

It supports 4 users at the same time (standard, 9 users option) to share screens and scan the QR code with your mobile phone to access the file link and save the file.

It takes learning to new heights while being easy on the eyes. Perfect for conference multimedia presentations, interactive lesson plans, or



SMART INTERACTIVE WHITEBOARD 55", 65", 75", 86", 98", 110"

Product Highlights



Smooth Writing

Adapt the latest IR tech, the whiteboard app allows users to smoothly write, draw, and erase on-screen through touch by any objects



4K Display

The original screen panel with A-class quality and 3840*2160P resolution, and NTSC>72%, offer users with a clear and vivid reviewing



Intelligent Recognize

Infrared Intelligent gesture recognition, the interactive digital board offer users zoom in / out with gestures, and erase on the screen



Stereo Sound

Embedded dual-channel Dolby sound the interactive panel will give the users and audiences a cinematic audio-visual experience



Eye-protection

The interactive screen has a filter to effectively reduce blue light so your eyes remain comfortable even when using the display for longer periods



Auto-adjust Brightness

built-in light sensor system, the interactive boards can automatically adjust the screen brightness per working environments



Professional Design

Our smart boards interactive has perfect appearance with professional design, the frame looks seamless and highly classical



Zero Bonding Tech

The advanced zero bonding technology which makes the IFP have a touch sensor more accurate, and dual-face anti-glared treatment



SPECIFICATIONS:

Model# HT-65D S Series

LCD Panel Parameter

Sizes	65inch
Screen Panel Type	D-LED/ IPS Screen
Assembled Tech	Zero Bonding
Display Area	1428.48*803.52mm
Resolution	3840*2160
Display Rate	16:9
Brightness (type)	>= 350 cd/m ²
Contrast	4000:1 / 1200:1 (IPS)
Pixel (mm)(H/V)	0.372*0.372 [68PPI]
Reviewing Angle	178°(H) / 178°(V)
Refresh Rate	60Hz
Colorful	10bit,10.7B
%NTSC	>72% NTSC (Standard), 90% NTSC (Option)
HDR	Support
Response time	≤6ms
Lifetime	Above 40,000 hrs

Android System

Android OS	Android 14.0 OS , mainboard #V100 (GK6760V100 /GK6780V100)
Android CPU	the flagship 8-core A55 CPU the main frequency up to 1.2GH
Android GPU	Quad-core MaliG52, 600MHz
Flash Nandi EMMC	128GB
RAM DDR3	8GB
Input Resolution	1920*1080/30Hz, 3840*2160/60Hz; 3840x2160@120Hz (Option)

Connectivity

Backside Ports	RJ45 In x1	
	RS232 x1	
	Earphone x1	
	Coax x1	
	TF x1	
	HDMI In x1	
	HDMI In(eARC) x1	
	TOUCH USB x1	
	Public USB2.0 x1	
	Public USB3.0 x1	
	VGA x1	
	VGA Audio In x 1	
	Option	HDMI out x1
		DP In x1
	RJ45 Out x1	
	MIC In x1	
	Optical x1	
Front Ports	USB3.0 x2	
	HDMI In x1	
	TOUCH USB x1	
	Type-C x1	
Front Button	Buttons x7 (standard)	

Camera/Audio/Microphone (Optional)

Camera	13MP Megapixels Option: 48MP Megapixels, 110° FOV AI function(option): Automatical voice tracking
Video Recording	3840*3024(4K); 60Hz
Microphone	8-array Microphone
Mic Pick Up Range	0 ~ 6 meters
Speaker Output Power	Standard: 2*15W; 1x20W Subwoofer (option)
NFC	Near to connectivity

Network

LAN	10/100M auto-identification and DHCP
WIFI	WiFi4 2.4G; WiFi5 2.4G+5G(option)
Bluetooth (Option)	Bluetooth 5.0

Light Sensor System

Pin hole light sensor on the frame, auto adjust the screen birghtness

PC Connectivity

OPS PC (Option)	Built-in OPS PC connectivity board, OPS Slot 80pin
-----------------	--

Power

Power Supply	AC200V to AC264V; , Magmet power board
Consumption (standby)	<0.5W
Consumption (max)	180W

Android Software

Whiteboard APP	3 pen styles & 2 intelligent brushes that can convert your handwriting into printed text/ pattern Annotation, insert picture, table, all kinds of shapes, chart drawing, video, and signal source
Screen Share	Scan QR to share screens under Whiteboard APP
Airplay / Mirror	Scan to download app for mirror screens between Android / IOS OS Option: the dongle to support Windows PC mirroring
Small Tools	Camera, Votekit, Timer, Stopwatch, Countdown Record, Screenshot, Easy Upload, Gallery Freezing, Split Screens
More Apps	Play store (user can download the other APPs from Google)
Languages:	Support multiple languages: english, france, spanish, arabic ...

Touch Technology

Touch Technology	Infrared touch technology with high accuracy , finger or any object touch
Touch Glass	4mm tempered glass, hardness>7H; dual-face anti-glared treatment
Touch Points	40 touch points, 20point writing
Touch Accuracy	3mm +/-
Resolution	32768*32768
Response time -single point	<=6ms
Touch refresh rate	>=140fps
Touch interface	USB
Support OS	Support WINDOWS /LINUX /MAC /Android
Touch times	above 6000millions times at same point

Physical

Frame Color	Deep Blue /Sliver /Black
Shell Materials	Aluminum frame Metal backside
Product Size	1483.8*886.9*115.8mm
Package Size	1615.8*220*1012mm
Net Weight	43Kg±1Kg
Gross Weight	53Kg±1.5Kg
VESA	500x400mm

What's in the carton

Touch Pen	x2, magnetic pen
HDMI Cable	x1, 1.5m length
USB Cable	x1, 1.5m length
Power Cable	x1, 1.5m length
Remote Control	x1, English language
Wall mount	x1, installation screws
Interactive Display	x1, packing with plastic bag, foam inside carton

Environments

Temperature	Working : 0°C to 40°C ; Storage : -20°C to 60°C;
Humidity	10%-90% RH at 40°C, non-condensing
Working Time	24/7 hours working

Certificate

CE	EMC, LVD, RED test
ROHS	Safety test
ISO	ISO9001 Quality Management
FCC	FCC Document

Dimensions:

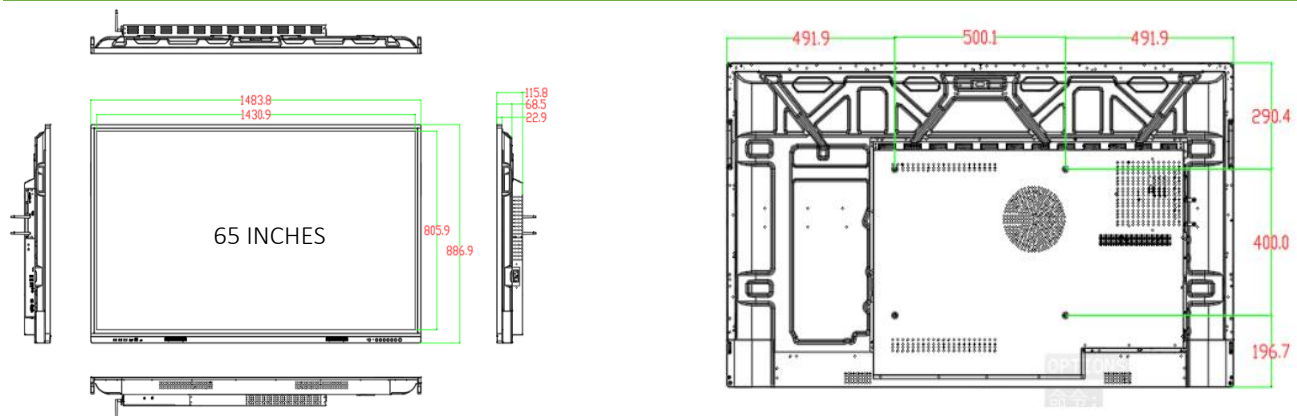

PRODUCT DETAILS

Perfect Design

The overall design of our interactive panels is seamless, with a touch of sophistication. The materials used are first class Ensures durability and a premium feel. Clean interface, making it easy to Catch people eyes

Variable Configuration

Our interactive panels boast cutting-edge technology With powerful processor ensures smooth and lag-free performance User can select the configuraiton per actual Requirements

Camera & Mic
Option: 13MP / 48MP



Handle

Classic Design

Seamless Integration, Brushed Painting Frame

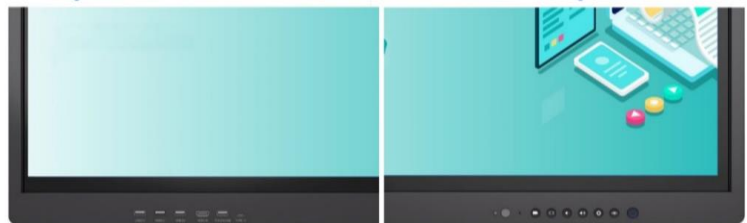

USB x 3, HDMI x1, Touch USB x1, Type-C x1

Light Sensor Pin Hole, Buttons x 7



OPS PC attachable

Intel I3, I5, I7 4th /6th /8th /9th /10th /11th Generation CPU
RAM: 4GB / 8GB /16GB
DDR3 / DDR4
Storage: 128GB / 256GB /512GB /1TB /2TB

Android Mainboard

Android 14.0 / 13.0 OS
(#V100 / #982 / #311D2 / #3588)
Option:
2GB/3GB/4GB/8GB RAM
16GB/32GB/64GB/128GB

Wireless Mirror Dongle



Video meeting, conference, school teaching, User can select it per actual requirements.

Attention: Above pictures just for reference, all subject to the actual device

BASIC OPTIONAL:

Dongle	Mirror dongle for Windows OS
OPS PC	Intel I3/ I5 / I7, the configuration to be customized
Mobile Stand	floor stand to support 55" ~110" interactive screens
Electric Stand	Electric Flip Stand / lift Stand to support 55" ~110" intractive panels
Manual Lift Device	Manual lift deice to support 55" ~110" interactive tvs

OPS PC

User can customize OPS PC per actual requirements, the configuration as the following

Intel® OPS-C Configuration

Processor	Intel I3, I5, I7, 4th/ 6th/ 7th/ 8th/ 9th /10th /11th GEN CPU
Chipset	Intel® HM86, H110, H310C, Z390
Memory	4GB / 8GB /16GB /32GB DDR3/DDR4
Storage	128GB / 256GB / 512GB / 1TB /2TB SSD / HDD SATA interface
Graphics	Intel® Integrated High Performance Graphics
WIFI	1 x M.2 2230 PCIe/USB interface / Bluetooth
LAN	Intel® i219V Gigabit Ethernet NIC
Sound card	ALC269 sound decoding chip
OS	Window 10 /11 OS (copy version) ; Linux OS

Dimension

195 x 180 x 30 mm /42mm

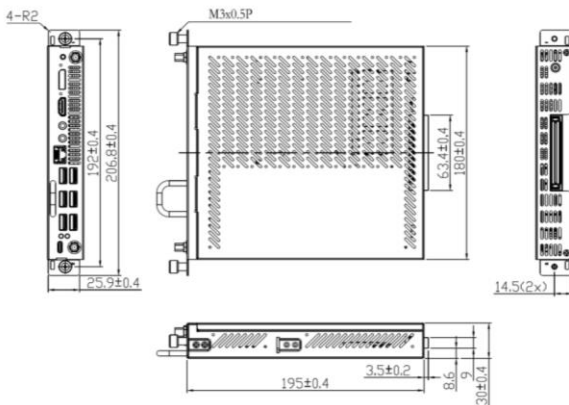

Power

12~19V 4.74A DC input, maximum 90 watts

FREE WHITEBOARD SOFTWARE

Vertical

Three Kinds of Display Modes

All kinds of education & lab tools
 Edit, annotation, dual screens/pens
 Intelligent gesture recognize
 Read, record, camera
 Multiple sources
 Countdown

Simple Icon

Horizontal

Free drag image & text from website into Whiteboard

Side Shortkeys

Free switch

Mutlpe Languages Options

So Easy and Vivid Teaching & Conference



Standard I/O (It's for the CPU above 10th GEN)

- 1x OPS 80-pin interface
- 1 x 3.0 Type-C port
- 1 x Power LED+HDD LED
- 6 x USB3.0 Type-A ports
- 1 x Gigabit Ethernet port
- 1 x 3.5mm audio output interface
- 1 x 3.5mm audio input jack
- 1 x HDMI1.4 display port
- 1 x System Recovery Button
- 1 x DP1.2 display interface
- 1 x reset/clear CMOS button
- 1 x switch button
- 2 x Antennas

Environments

- Working temperature: -10°C~50°C
- Working humidity: 10%~90%, non-condensing
- Storage humidity: -20°C~70°C

The Actual Interfaces:



WHY CHOOSE US ?

Patient & Various Service

Directly factory offer with OEM, ODM, and SKD brand products
Even 1pcs support also
You will get a reply within 24~48 hours for any inquiries

Serious Quality Control

Original screen, Dust-free workshop assembling, 24~48 hours aging
One by one inspection before the goods packing
CE, ROHS, ISO, FCC Document certificate

Non-worried Shipment

We will assist you to arrange well transportation per your requirements. include shipping cost comparing check, wooden pallet settled, EXW, FCA, FOB, CFR CIF, DAP, DDP ... terms

Lifetime Technical Support

throughout the duration of your warranty and even after your warranty has expired we are here to support you. anytime we can provide free technical support by online, tel, and email.

Extended Warranty

Usually the interactive display come with 1 year commercial warranty as standard but if you want to extend this you can upgrade this to over a 3~5 year period at point of purchase.

Advanced Replacements

With along the bulks together, we will offer 1% spare parts to you in case any of the faulted parts. free charge replacement during warranty.

Witness of Global Clients

Our products and service have been gotten " Good | Very Good " reviews by above 99% of clients from more than 30 countries and areas.

THANK YOU

Tel: +86 13582949978
Email: info@itatouch.com
Website: <https://www.itatouch.com>
<https://www.hitatouch.com>

Let's grow together to be top suppliers in the industry!

We are willing to do more works to provide greater service and lower the cost of customers. Customer's benefits always come first. Be positive to work, willing to help, share the responsibility and achievement of our team

